

Application Note

SA40072 – 4 to 20Ma Signal Conditioner Technical Information and Calibration Instructions

Dimensions, Electrical Connections and Potentiometer Locations (dimensions in inches)

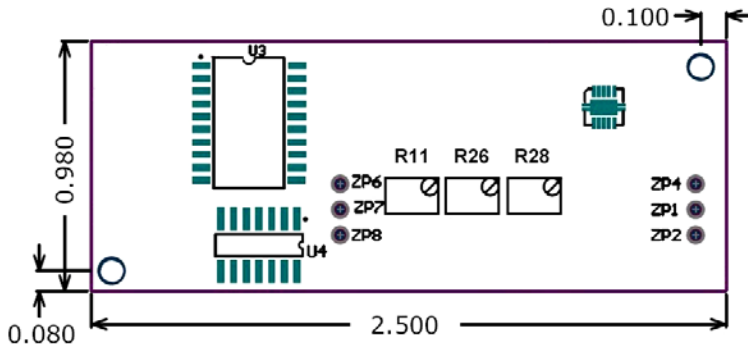

Adjustment Potentiometers

PCB Location	Function
R28	Null (12mA)
R11	Positive Output (20mA max.)
R26	Negative Output (4mA min.)

Input/Output Connections

PCB Location	Function
ZP1	Input Voltage
ZP2	Ground
ZP4	4-20mA output
ZP6	sensor electrode 'A'
ZP7	sensor electrode 'B'
ZP8	sensor neutral (center)

Typical Current Consumption

Input Voltage	Output (mA)	Input Current Draw (mA @ ZP1)
24	-12	18.7
14	-12	18.7
14	-19	26.7
24	-19	26.7
24	0	6.4

Note: Negative current out of circuit, positive current into circuit.

Output deviation versus input voltage level

- Input Voltage Range (ZP1) : +14VDC to +24VDC
- Output Current Δ (ZP4) : $\pm 1-2\mu A$



SPECTRON SYSTEMS TECHNOLOGY INC.

595 OLD WILLETTS PATH
HAUPPAUGE NY 11788
PHONE: 631 582-5600
FAX: 631 582-5671

www.spectronsensors.com

Specifications are subject to change without notice!



Doc.# SAN-221-3308

Application Note

SA40072 – 4 to 20Ma Signal Conditioner Technical Information and Calibration Instructions

Output Ripple (noise)

Output (mA)	Load (ohms)	Ripple (uA @ 600Hz)
19	475	38
12	475	2
5	475	38

Recommended circuit to reduce noise

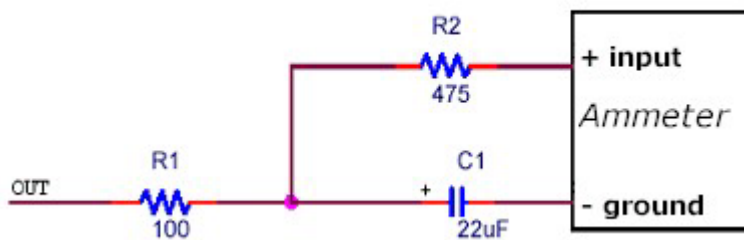

Output Load Chart

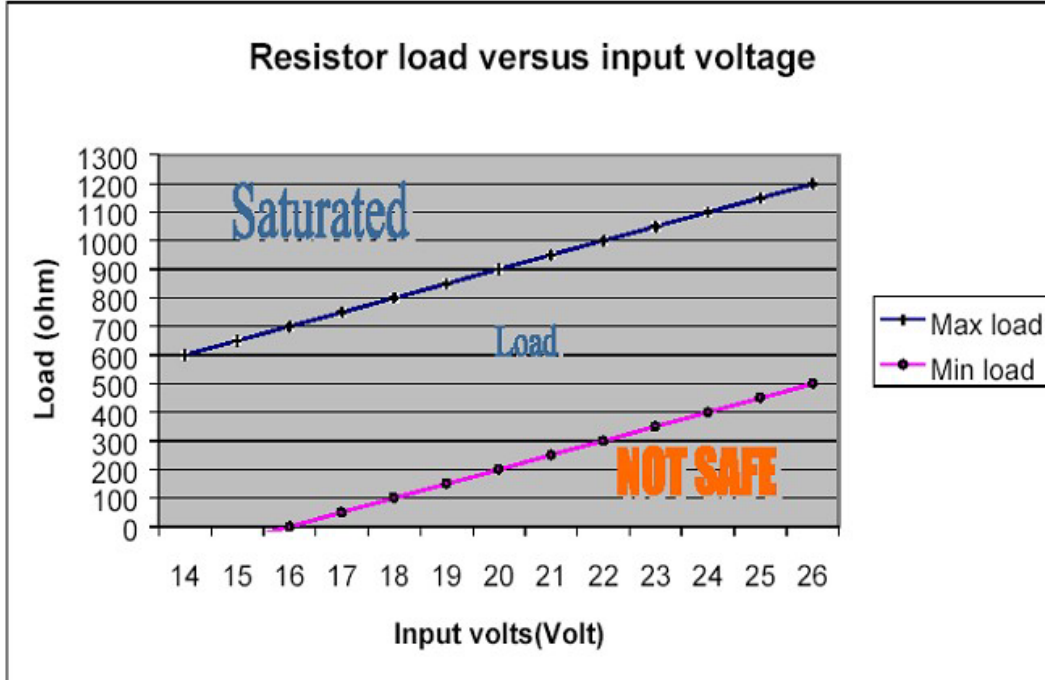

SPECTRON SYSTEMS TECHNOLOGY INC.

595 OLD WILLETS PATH

HAUPPAUGE NY 11788

PHONE: 631 582-5600

FAX: 631 582-5671

www.spectronsensors.com

Specifications are subject to change without notice!



Doc.# SAN-221-3308

Application Note

SA40072 – 4 to 20Ma Signal Conditioner

Technical Information and Calibration Instructions

Calibration Instructions

NOTE: Performing this calibration will void any and all factory calibration settings!!

1. Solder the lead wires from the tilt sensor to terminal numbers ZP6, ZP7 and ZP8 on the SA40072 Signal Conditioner, per the Input/Output Connection chart above.
2. Using the 'Output Load Chart' in Figure 1 above, select a proper value load resistor according to the input voltage that will be used.
3. Connect one end of the resistor selected above to the positive (+) input terminal of an ammeter. Connect the other end of the resistor to ZP4 on the the SA40072. Connect the ground terminal of the ammeter to ZP2 on the SA40072.
4. Connect the DC power supply to terminal numbers ZP1 (+) and ZP2 (-) on the SA40072 respectively.
5. Turn on DC power supply.
6. Place tilt sensor in the level (null) position. Wait at least 20 seconds for sensor to settle.

Note: sensors with higher fluid viscosities (i.e. damped) may require a longer waiting period!

7. Turn 'Sensor Null Adjustment' potentiometer R28 until the ammeter reads 12.0mA.
8. Rotate the tilt sensor in a counter-clockwise (negative) direction to half of the desired angular measurement range. Wait at least 20 seconds. Adjust potentiometer R26 to obtain an 8.0mA reading on the ammeter.
9. Return sensor to the null position. Wait at least 20 seconds for sensor to settle. If sensor reads 12.0 mA's, continue on to step #10. If not, repeat step #'s 6 through 9 until no adjustments are necessary.
10. Rotate tilt sensor in a clockwise direction to half of the desired angular measurement range. Wait at least 20 seconds. Adjust potentiometer R11 to obtain a 16.0mA reading on the ammeter.
11. Return sensor to the null position. Wait at least 20 seconds for sensor to settle. If sensor reads 12.0 mA's, calibration is considered complete. If not, repeat steps #6 through #11 until no adjustments are necessary throughout entire cycle.



SPECTRON SYSTEMS TECHNOLOGY INC.

595 OLD WILLETTS PATH
HAUPPAUGE NY 11788
PHONE: 631 582-5600
FAX: 631 582-5671

www.spectronsensors.com

Specifications are subject to change without notice!



Doc.# SAN-221-3308