

Sensor Housing - Model #556A for L Series Electrolytic Tilt Sensors



The **L Series Electrolytic Tilt Sensors** are all available pre-installed into the following precision machined housing. This housing not only promotes ease of handling, but also provides protection from potentially hostile environments. The sensing element is encased in silicon rubber, which seals the sensor from moisture ingress, and helps prevent null drift by insulating the sensor from steep temperature gradients. The housing reference surfaces are leveled to within 9 arc seconds of the true horizontal and vertical planes, while the sensing element is mounted to within 1 arc minute of the reference surfaces. This not only simplifies the installation and alignment process, but virtually eliminates the effects of cross coupling when mounted parallel to the axis of rotation.

General Specifications

Housing..... #556A
 Sensor..... L Series
 Mounting orientation..... Dual axis, horizontal
 Material Al 6061 (aluminum)

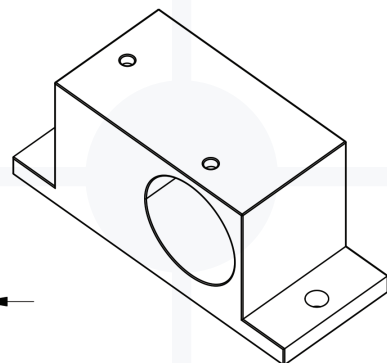
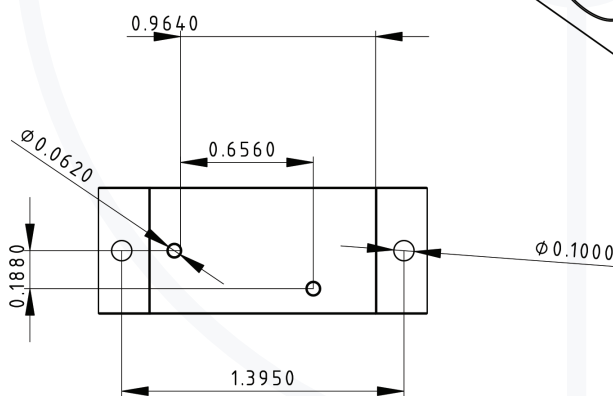
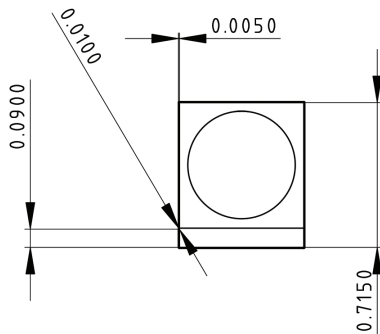
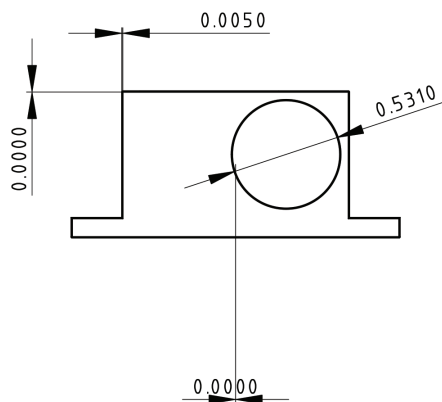
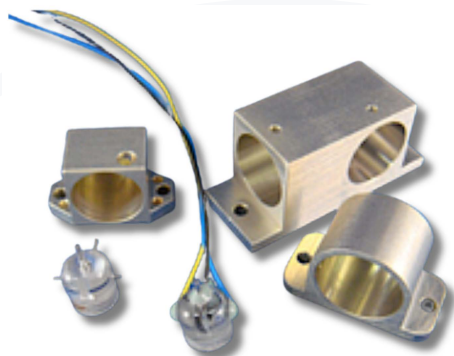

***Consult factory for detailed communication protocol information!**